

New Physics and the Electron-Ion Collider (II)

Hooman Davoudiasl

High Energy Theory Group, Brookhaven National Laboratory



The 2026 CFNS Summer School on the Physics of the Electron-Ion Collider
June 1-12, 2026, Stony Brook University

From last lecture:

EIC and New Physics

- We will consider two large classes of beyond SM (BSM) physics*:
 - (I) Heavy physics, indirect signals
 - (II) Light physics, perhaps from dark/hidden sectors, direct signals
- Class (I) signals generally require precision
 - Could be formulated in the language of SM effective field theory (SMEFT)
 - Beam polarization can be leveraged
- Class (II) physics could lead to direct detection of new particles
 - A variety of models
 - Access to new states around the GeV scale
 - Large atomic number ions can provide Z^2 enhanced coherent cross sections

* These lectures: only a sample of possibilities; unfortunately many interesting works not covered

SMEFT Constraints at LHC and EIC

Example

- 4-fermion operators: deep inelastic scattering (DIS) and Drell-Yan processes
Boughezal, Petriello, Wiegand, 2004.00748
- Drell-Yan: $pp \rightarrow l\bar{l}$ ($q\bar{q} \rightarrow l\bar{l}$), LHC ; DIS: $lp \rightarrow l'X$ ($lq \rightarrow l'q'$), EIC

$\mathcal{O}_{lq}^{(1)}$	$(\bar{l}\gamma^\mu l)(\bar{q}\gamma_\mu q)$	\mathcal{O}_{lu}	$(\bar{l}\gamma^\mu l)(\bar{u}\gamma_\mu u)$
$\mathcal{O}_{lq}^{(3)}$	$(\bar{l}\gamma^\mu \tau^I l)(\bar{q}\gamma_\mu \tau^I q)$	\mathcal{O}_{ld}	$(\bar{l}\gamma^\mu l)(\bar{d}\gamma_\mu d)$
\mathcal{O}_{eu}	$(\bar{e}\gamma^\mu e)(\bar{u}\gamma_\mu u)$	\mathcal{O}_{qe}	$(\bar{q}\gamma^\mu q)(\bar{e}\gamma_\mu e)$
\mathcal{O}_{ed}	$(\bar{e}\gamma^\mu e)(\bar{d}\gamma_\mu d)$		

From 2004.00748

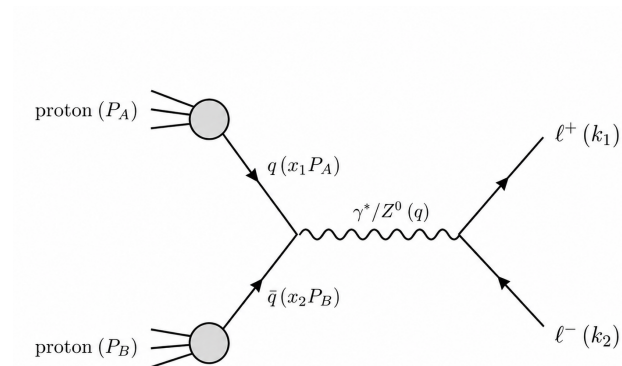
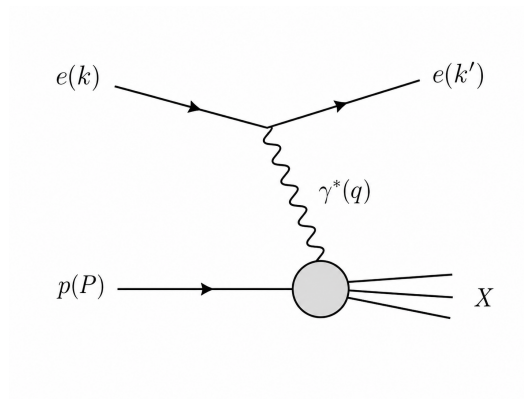

- $\sim 20 \text{ fb}^{-1}$ of ATLAS data at $\sqrt{s} = 8 \text{ TeV}$ (1606.01736)
- EIC: $\sqrt{s} \approx 140 \text{ GeV}$, 70% e, p polarization
- EIC integrated luminosity: 10 and 100 fb^{-1}
- DIS cross section: taking advantage of both e and p polarizations
- Removing flat LHC directions:

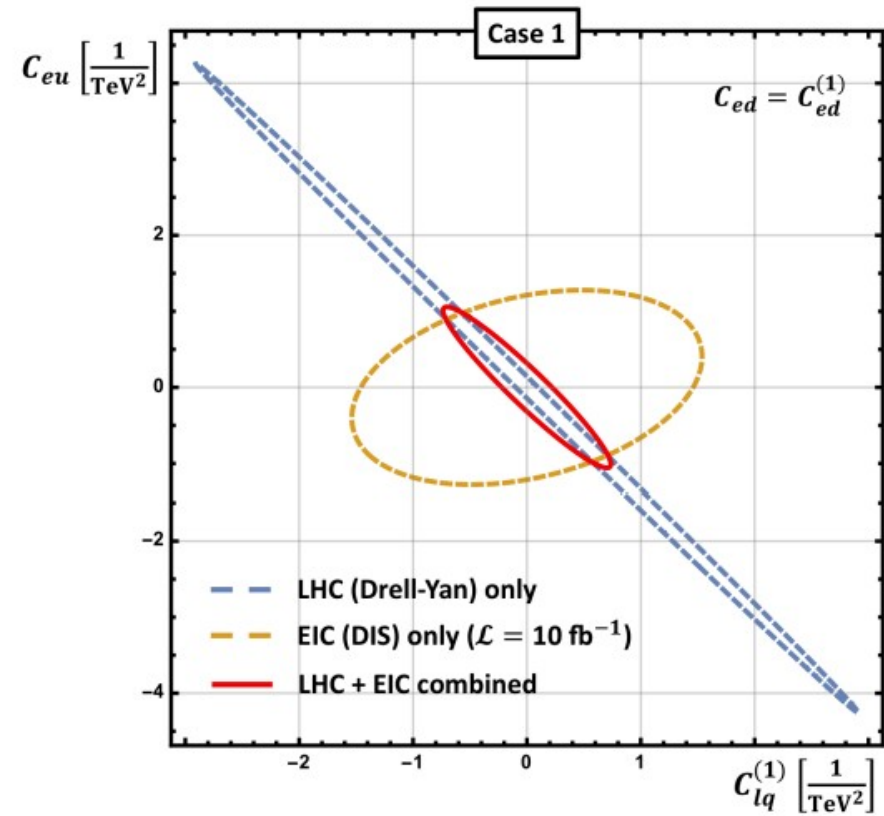
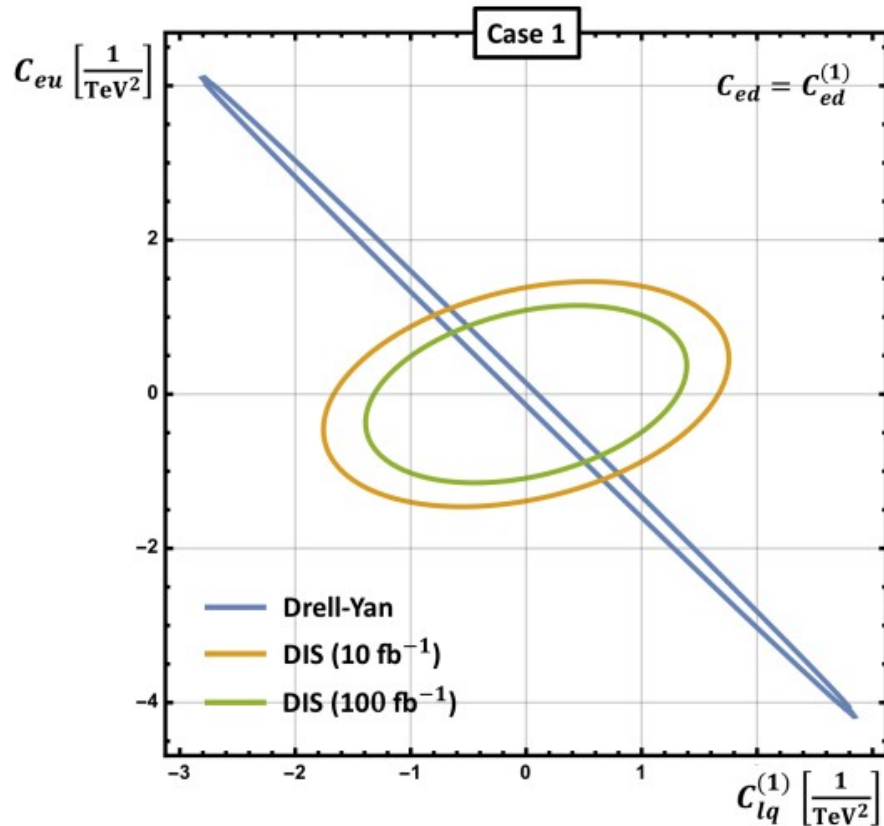

From 2004.00748 (Contours: 68% C.L.)

Charged Lepton Flavor Violation (LFV)

- Could be mediated by, e.g., t channel heavy (> 1 TeV) leptoquarks at EIC
Early work by: [Gonderinger, Ramsey-Musolf, 2010](#)

- Leptoquark: color charged; couples to quarks and leptons

[Cirigliano, Fuyuto, Lee, Mereghetti, Yan, 2102.06176 \(figures\)](#)

- Bounds on the induced 4-fermion operators (dim-6)

- From LHC, low energy (τ , B , decays)

- Competitive EIC bounds, depending on operator

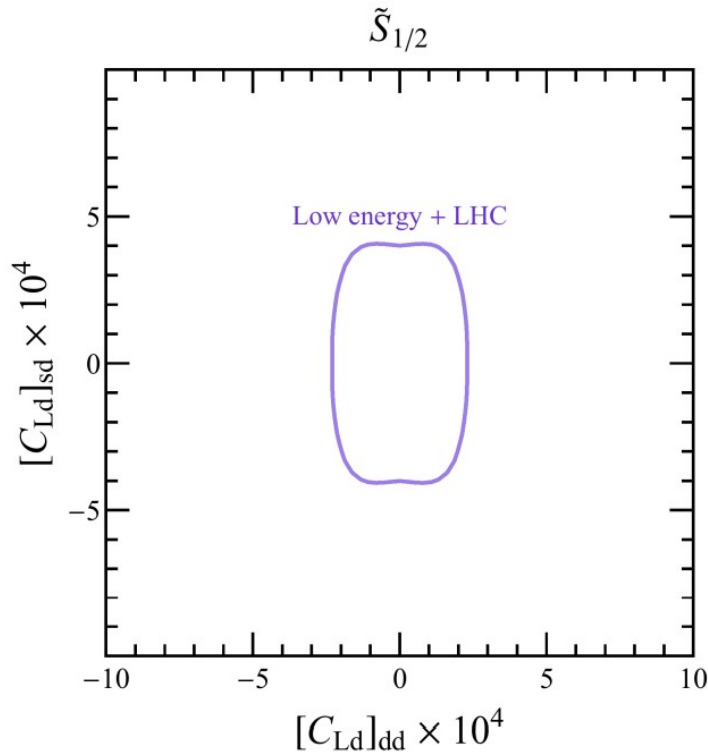
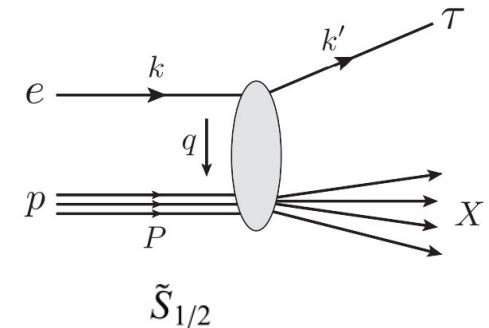

$\sqrt{s} = 141$ GeV, 100 fb^{-1}

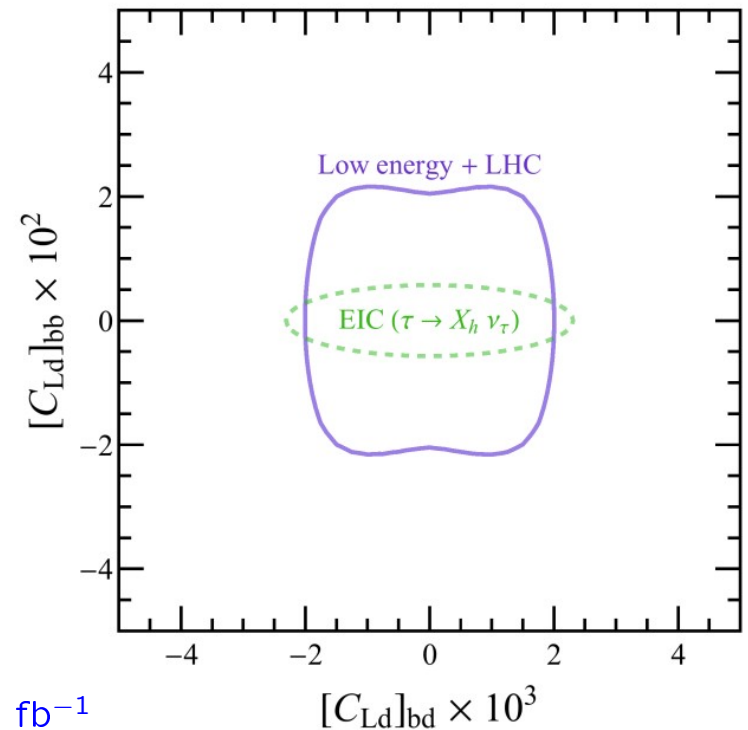

SM Electroweak Parameters; $\sin^2 \theta_W$

- Running $\sin^2 \theta_W(Q^2)$: fundamental parameter of SM electroweak sector
- Has been measured in atomic, fixed target, and Z -pole measurements
- EIC offers access to intermediate Q^2 regime

From Bougezal et al., 2204.07557

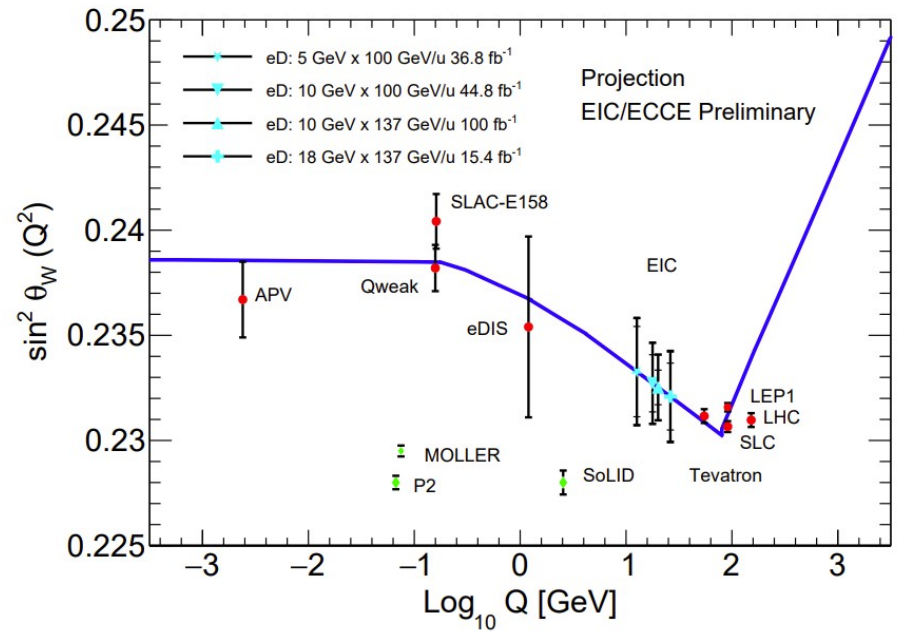
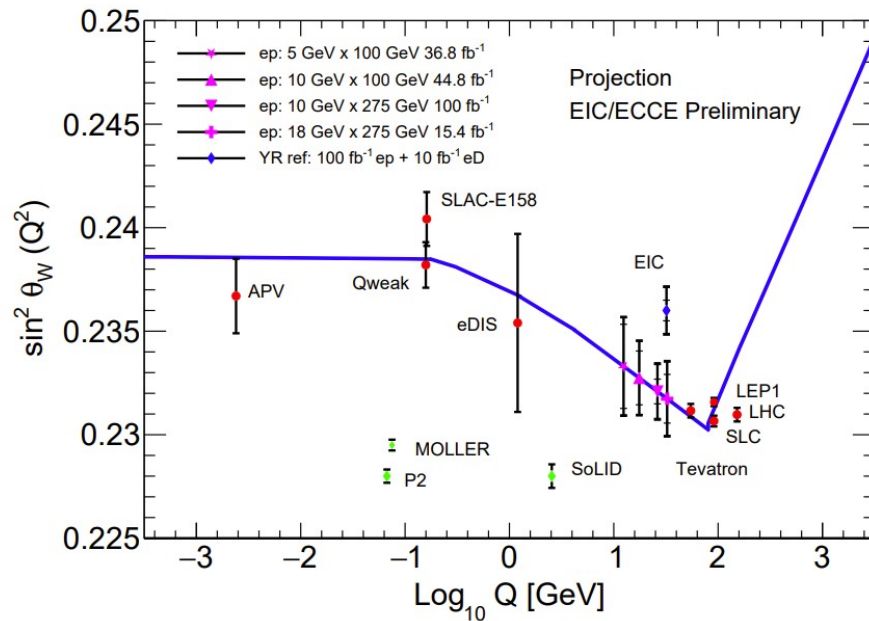

Electron beam polarization: 80% with 1% uncertainty

Left panel: ep ; Right panel: eD

Charged LFV via ALPs at the EIC H.D., Marcarelli, Neil, 2112.04513

- EFT for ALP interactions

$$\mathcal{L}_\ell = \frac{C_{\ell\ell'}}{\Lambda} a \sum_{\ell\ell'} \bar{\ell} (m^- \sin \theta_{\ell\ell'} - m^+ \cos \theta_{\ell\ell'} \gamma_5) \ell' + \text{H.C.} \quad ; \quad m^\pm \equiv m_\ell \pm m_{\ell'}$$

See, e.g., Bauer, Neubert, Renner, Schnubel, Thamm, 2019; Cornella, Paradisi, Sumensari, 2019

- $\theta_{\ell\ell'} = 0$: P even; maximal PV for $\theta_{\ell\ell'} = \pi/4, 3\pi/4$ (only L, R coupling)
 - Probed via polarized e -beams
- Search for $e - \tau$ LFV in coherent $eA_Z \rightarrow \tau A_Z a$; $A_Z = \text{Au}; Z = 79$

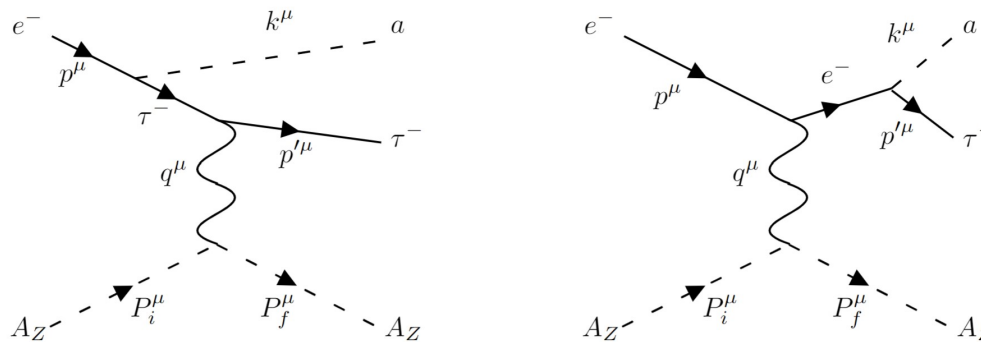

- Main decay channels: (i) $a \rightarrow \tau^- \tau^+$, (ii) $a \rightarrow \tau^- e^+$, (iii) $a \rightarrow \tau^+ e^-$
- Consider $a(\rightarrow e^+ \tau^-) \tau^-$ final state; veto on e^-
- Three-pronged τ decays; efficiency $\epsilon_\tau \approx 1\%$ from Zhang *et al.*, 2207.10261
 - Other decay modes and veto of ion break-up can enhance the search

- Main background from τ pairs through Bethe-Heitler process
 - Estimated from τ pair production in rock by cosmic ray muons [Bulmahn, Reno, 2008](#)
- Good EIC prospects for probing charged LFV ALPs, especially with diagonal couplings suppressed
 - Weakened τ decay constraints
- Adding μ detection may improve the search (τ identification)

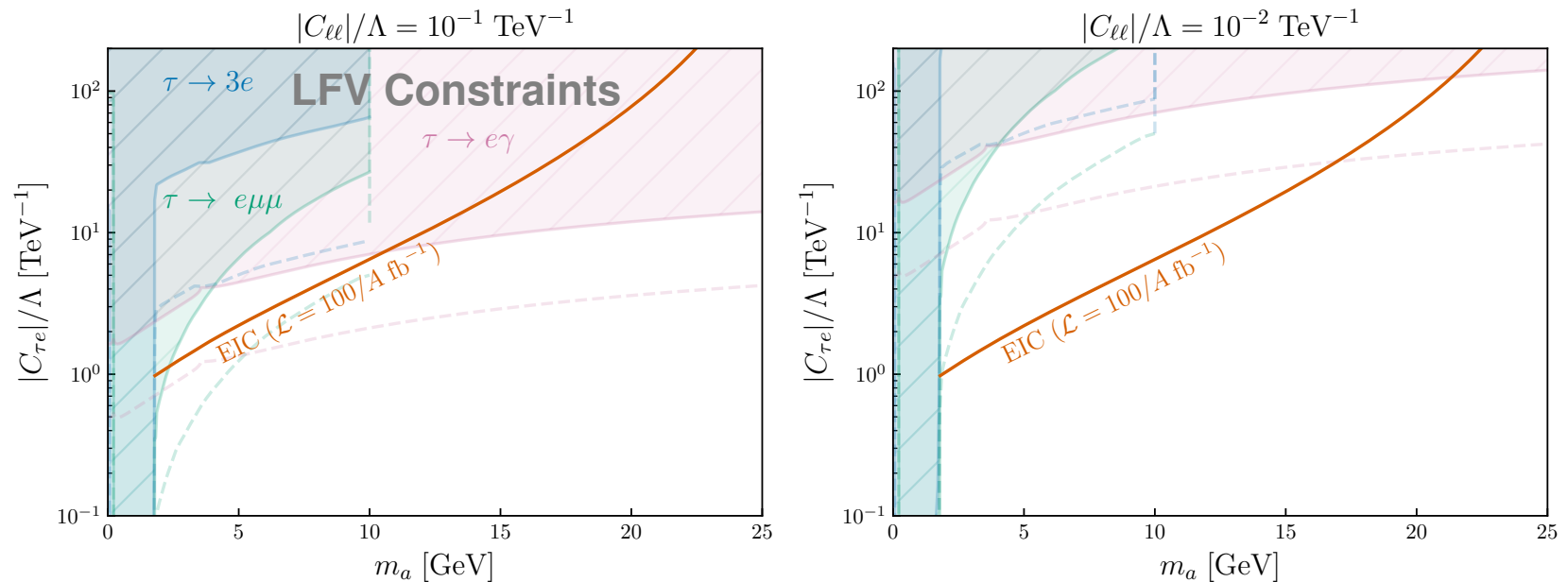

Solid line BABAR, dashed line Belle II with 50 ab^{-1} ; tree-level $a\gamma\gamma$ ignored

From H.D., Marcarelli, Neil, 2112.04513

Heavy Neutral Leptons at the EIC Batell, Ghosh, Han, Xie, 2210.09287

- HNLs arise in a variety of models; good example type I seesaw for $m_\nu \neq 0$
- Coupling to SM: $yHLN$

H Higgs doublet L lepton doublet in SM; N HNL

- After EWSB: N mixes with SM neutrinos

→ $\ell WN, \nu_\ell ZN$ couplings ($\ell = e, \mu, \tau$)

- Production in $e + p/A \rightarrow N + X$:

- Through charged current

- Depends on e -flavor mixing parameter U_e

- Simplified setup: one HNL and only $U_e \neq 0$

- Phenomenological approach: mass m_N and mixing U_e free parameters

- Both Dirac and Majorana N considered

- N decays: prompt and displaced, as well as invisible (dark sector)

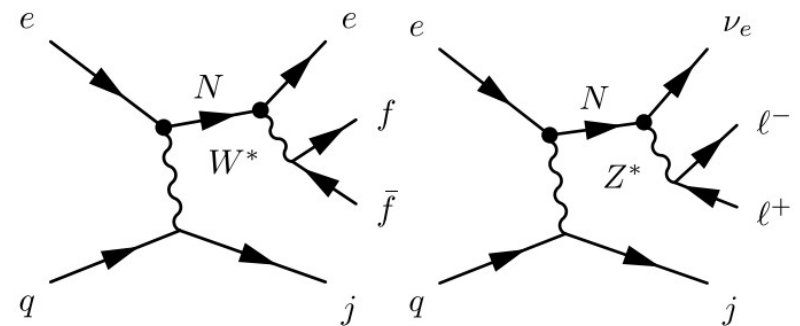

From 2210.09287

- $\sqrt{s} = 141 \text{ GeV}$, $\mathcal{L} = 100 \text{ fb}^{-1}$, $P_e = 70\%$

Figures from 2210.09287

- Unpolarized PDFs, proton beam

- Visible decays (right):

- prompt (95% CL)
- displaced (5 events)

- Invisible decays (below):

- mono-jet

- $\mathcal{S} = S/\sqrt{B + (\epsilon B)^2}$

- fractional systematic uncertainty ϵ

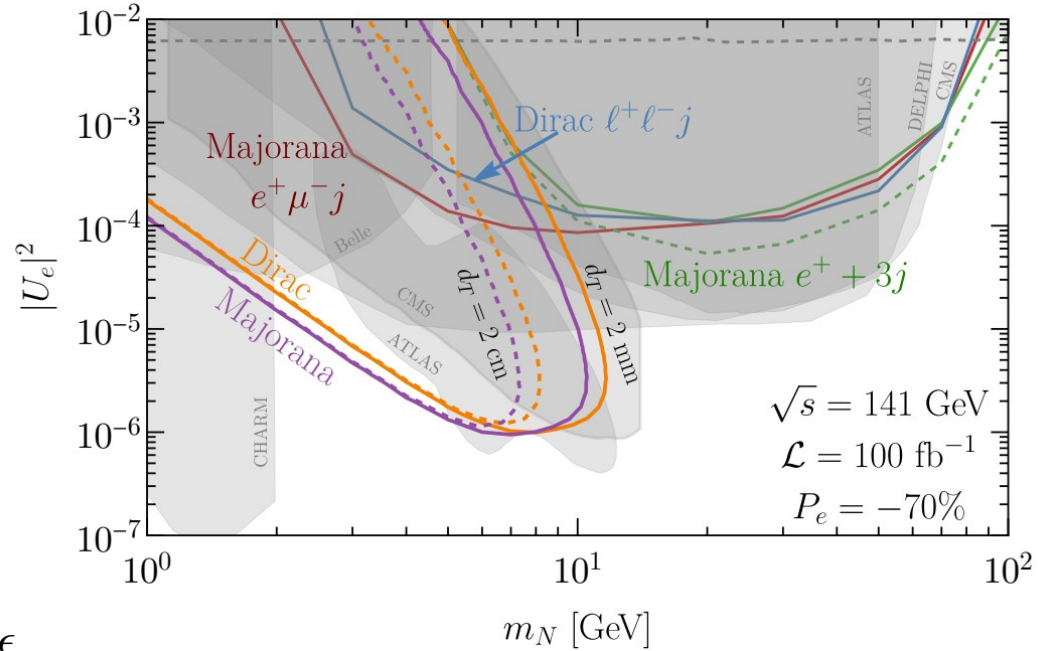

(LNV for Majorana N)

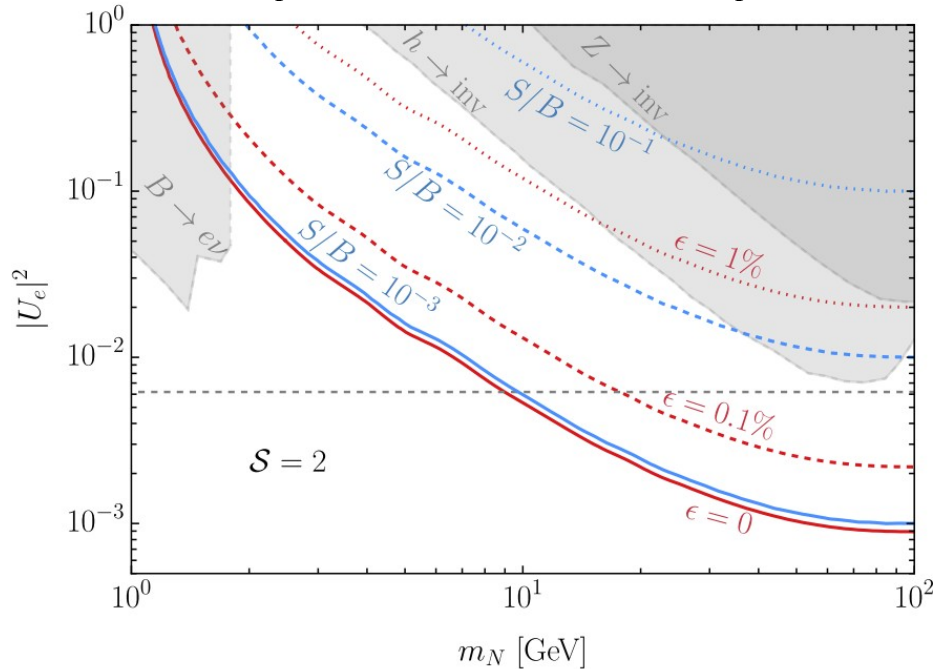

Displaced Hidden Vectors at the EIC

H.D., Marcarelli, Neil, 2307.00102

- Coherent production from gold ion, $Z = 79$: $eA_Z \rightarrow eA_Z A'$ ($Z_d \leftrightarrow A'$)
- $q^2 \lesssim \mathcal{O}(100 \text{ MeV})$
- Large Z^2 enhancement of electromagnetic scattering

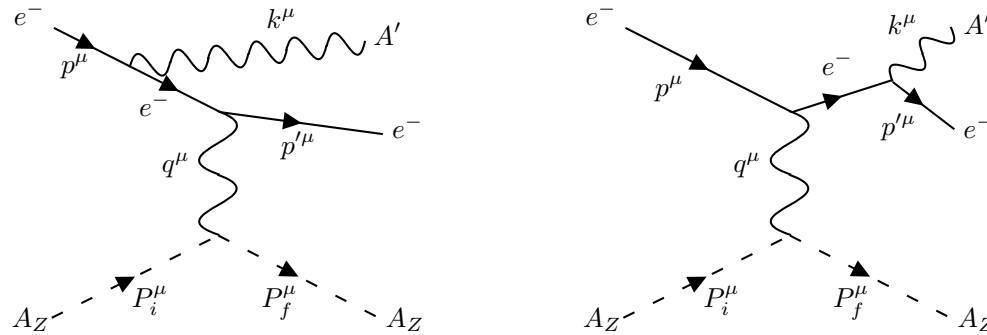

- Probability of detection of displaced decay: $P_{\text{disp}} = e^{-d_{\text{min}}/(\gamma_k v_k \tau)} - e^{-d_{\text{max}}/(\gamma_k v_k \tau)}$
- d_{min} from detector resolution, d_{max} from geometry γ_k boost, v_k velocity, τ lifetime
- We take $E_e = 18 \text{ GeV}$ and $E_A = 110 \text{ GeV/nucleon}$

Signal Selection:

- Assumed EIC Comprehensive Chromodynamics Experiment (ECCE) detector [arXiv:2209.02580](https://arxiv.org/abs/2209.02580) [physics.ins-det]
- Now the **ePIC** (Electron-Proton/Ion Collider) detector, similar capabilities
- Signal requires both e^+ and e^- from $A' \rightarrow e^+e^-$

$\mu^+\mu^-$ also available for much of the parameter space

- We estimated: $d_{\min} \approx \gamma_k (\text{DCA}_{2\text{D}}^{\min}) / (v_k \cos \theta_k^{\text{lab}})$
- For pions: $\text{DCA}_{2\text{D}}^{\min} < 100 \mu\text{m}$ **DCA: distance of closest approach**
- $\Rightarrow d_{\min} \gg 0.1 \text{ mm}, d_{\max} = 1 \text{ m}$

- ECCE tracking: $|\eta| < 3.5$

- We also considered a detector at $z = -5 \text{ m}$

Further details of the current detector design may push this farther back; also a possibility for a second detector

- Assumed: $\text{DCA}_{2\text{D}}^{\min} = 200 \mu\text{m}, d_{\max} = 5 \text{ m}$
- Covering far backwards (FB): $-6 < \eta < -4$

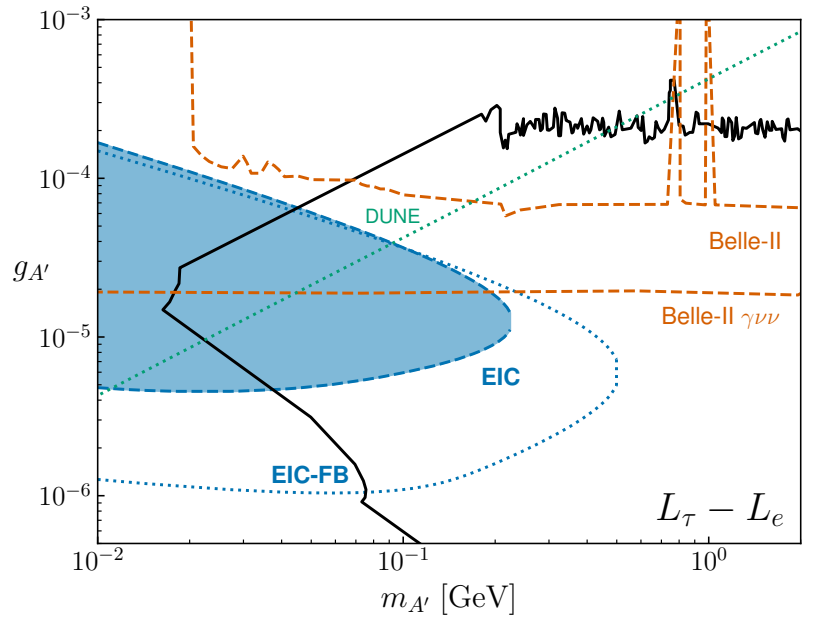
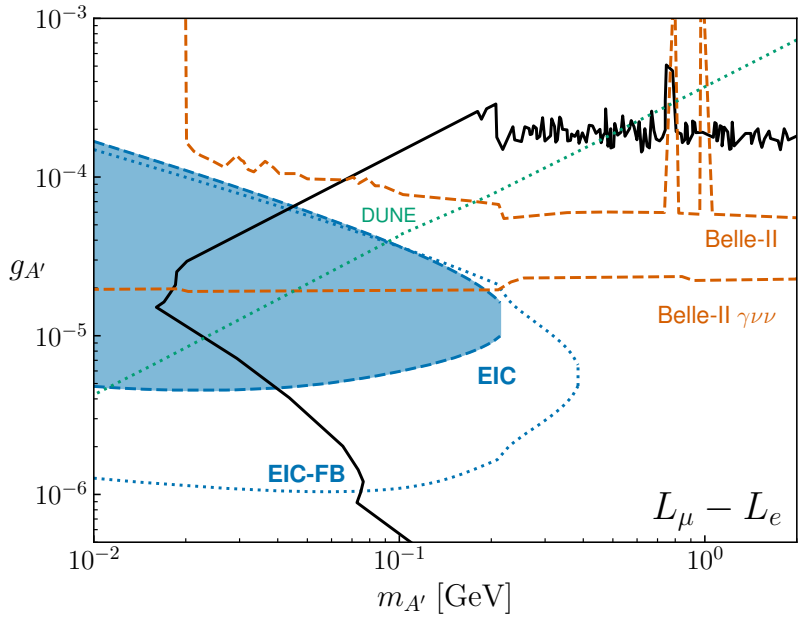
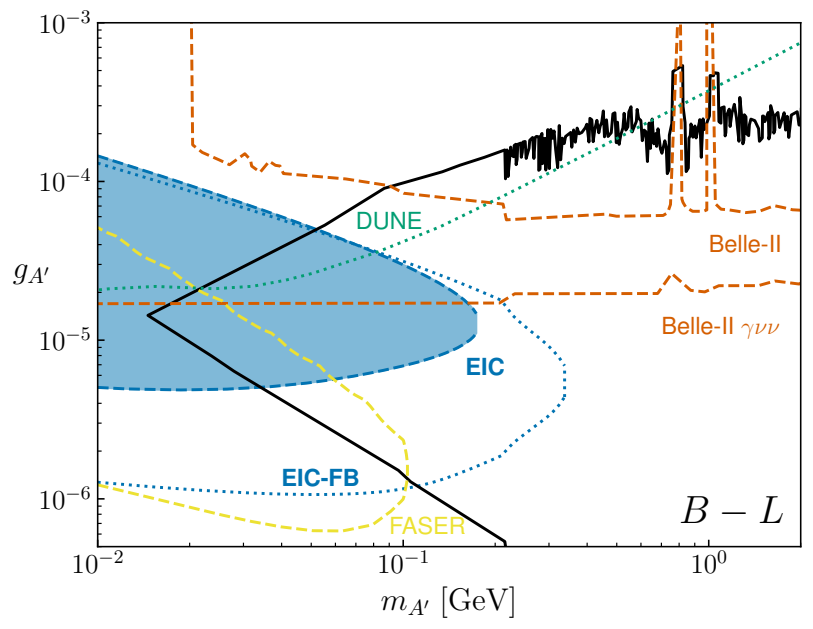
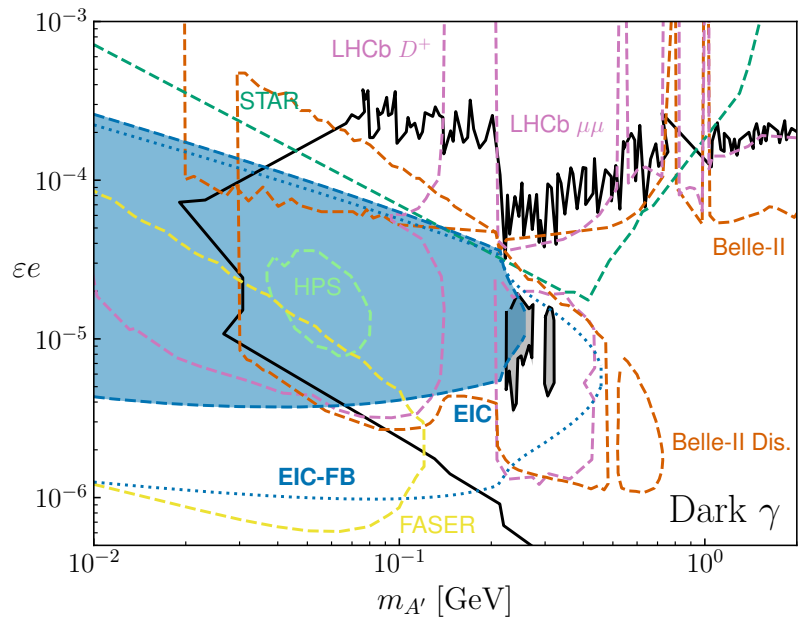

From H.D., Marcarelli, Neil, 2307.00102

Background considerations

- We assumed zero background
- Photon conversion: sparse backwards detector systems [Adkins et al., 2209.02580](#)
- Si disks separated by ~ 25 cm: cut out thin regions from signal

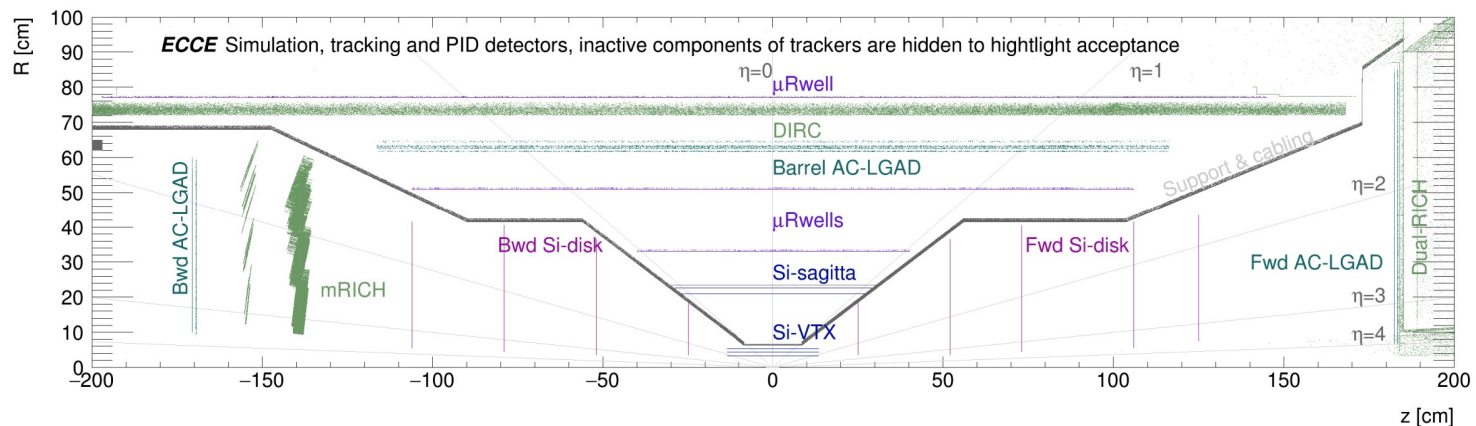

- Misidentified pions as electrons: electron end cap fake rate $\sim 10^{-4}$
- Requiring both e^+ and e^-
- Additional signals if muon detectors added
- Losing signal events down the beam pipe: our estimate $\sim (20-30)$ %, manageable
- These are (theorist) projections, using rough approximations
- Detailed and more realistic simulations required for definitive results

Also [Balkin et al., 2310.08827, JHEP 02 \(2024\) 123](#)

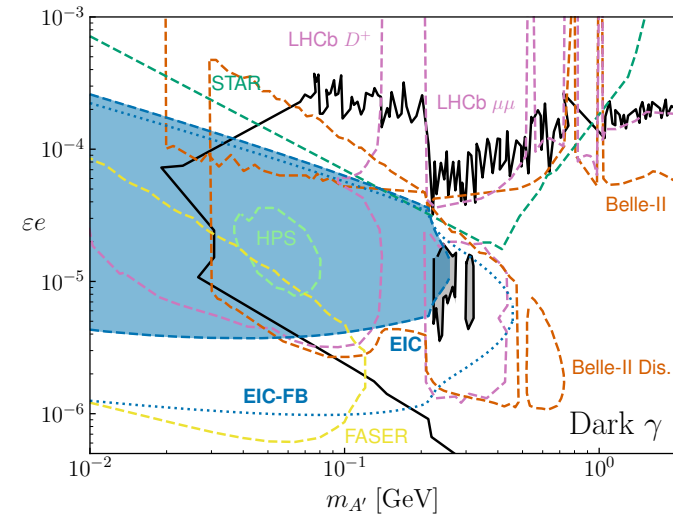
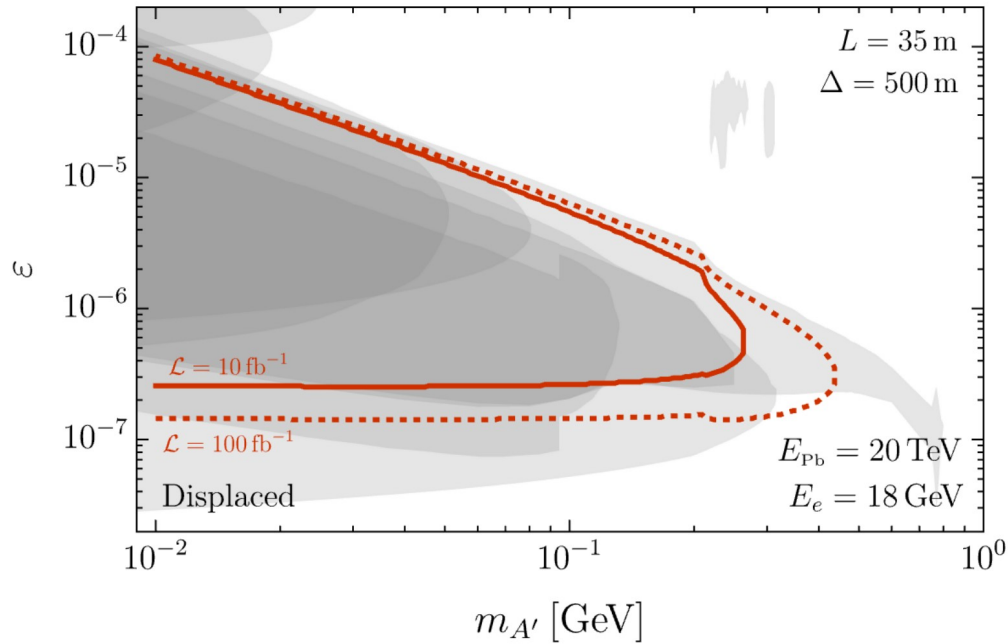

- $eN \rightarrow eNA'$, coherent scattering from Pb
- Dark photon decay $A' \rightarrow \mu^+\mu^-$ (to reduce background)
- Decay volume $\Delta = 500$ m long (shielded) at $L = 35$ m from interaction point
- Does not exceed current bounds
 - 2307.00102 assumed much smaller (\gtrsim mm) displacement (note different ε regime)
 - Worthwhile to determine efficiency of our suggested background suppression

[2307.00102](#)

- Work on ALP-photon coupling using coherent scattering at the EIC
- Z^2 enhanced From Balkin *et al.*, 2310.08827

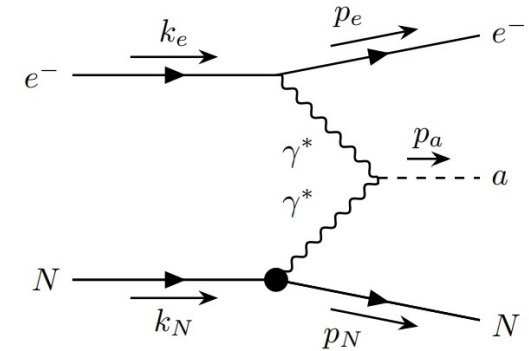
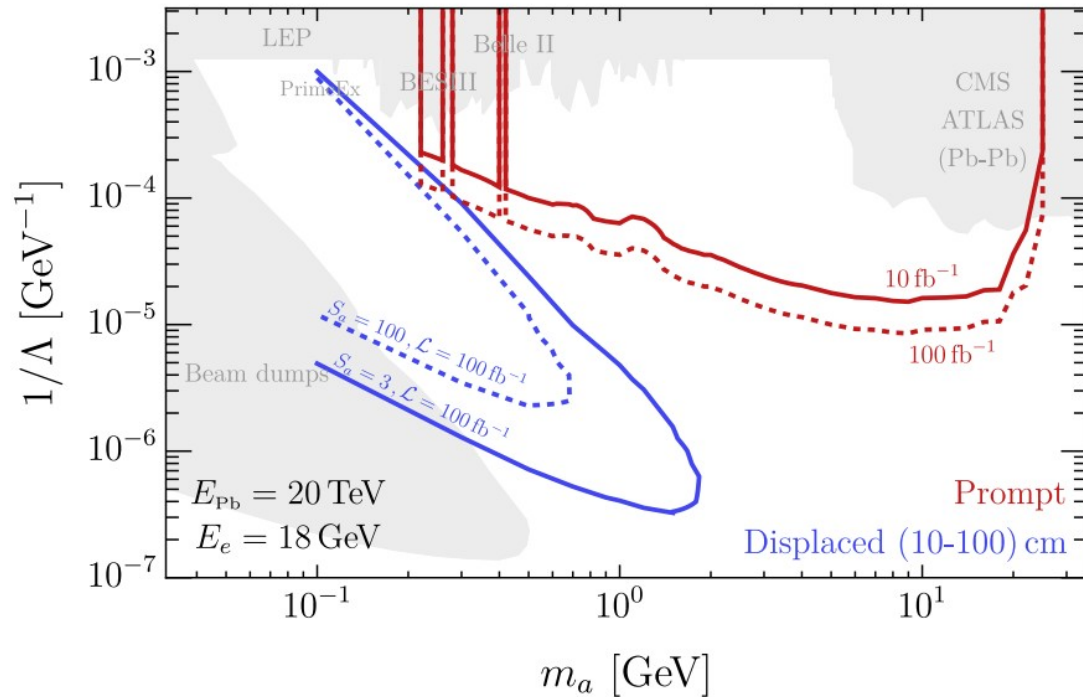

Figure 7: The EIC projections from the ALP searches with $E_e = 18$ GeV and $E_{Pb} = 20$ TeV. The solid (dashed) red lines show the prompt search results with 10 (100) fb^{-1} integrated luminosity. The solid (dashed) blue lines show the displaced search results with $S_a = 3$ ($S_a = 100$) with 100 fb^{-1} integrated luminosity, assuming the diphoton spatial resolution $L_R = 10$ cm and the distance between the interaction point and the EM calorimeter $L_{EM} = 100$ cm.

See also Liu, Yan, 2112.02477, Chin.Phys.C 47 (2023) 4, 043113 (e, p initial states)

Discovering Invisible Dark Bosons at the EIC

A. Electron beam production [H.D., Liu, 2505.08871](#)

- Consider dark bosons in ~ 10 MeV-10 GeV mass regime
- Weakly coupled to electrons, $\mathcal{O}(1)$ invisible branching fraction:
 - $B - L$, $L_e - L_i$ with $i = \mu, \tau$, dark Z , ...
 - Significant invisible branching fraction from ν or "dark sector" final states
- Basic models
$$\mathcal{L}_S = g_S^e \phi \bar{e}e + g_S^\chi \phi \bar{\chi}\chi$$
$$\mathcal{L}_V = g_V^e \phi_\mu \bar{e}\gamma^\mu e + g_V^\chi \phi_\mu \bar{\chi}\gamma^\mu \chi$$
 - ϕ (ϕ_μ) a scalar (vector)
 - χ : ν or dark fermion; $\phi \rightarrow \bar{\chi}\chi$ allowed on-shell
- We consider coherent e -Au scattering
- $E_e = 18$ GeV, $E_A = 100$ GeV per nucleon

Kinematics

- Emitted ϕ takes most of the electron beam energy
- Momentum transfer Q^2 mostly on the electron side
- SM background marked by soft and similar Q^2 from either beam

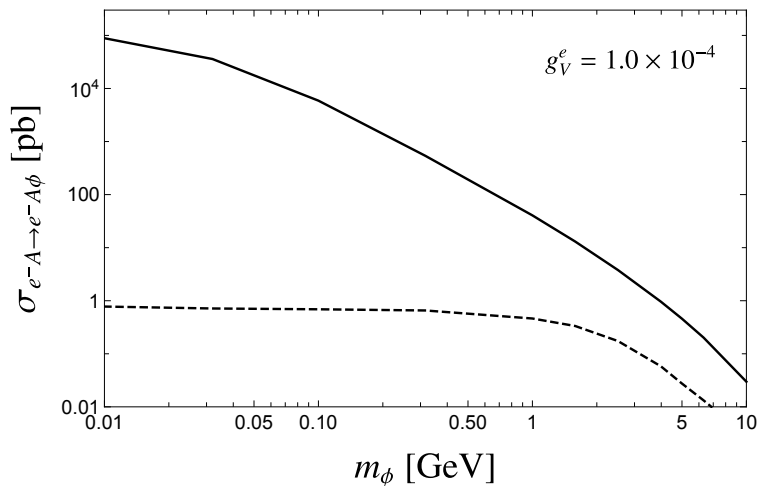

- We focus on the vector case
- Similar cross sections for scalars
- Dashed curve after cuts
- A main background: coherent $e^-A \rightarrow e^-A \gamma$, with γ missed
- E_e cut \rightarrow background E_γ mostly > 5 GeV, *Inefficiency* $10^{-6} \leq \epsilon \leq 10^{-4}$
 - for $|\eta_\gamma| < 3.5$ (assumed missed otherwise)

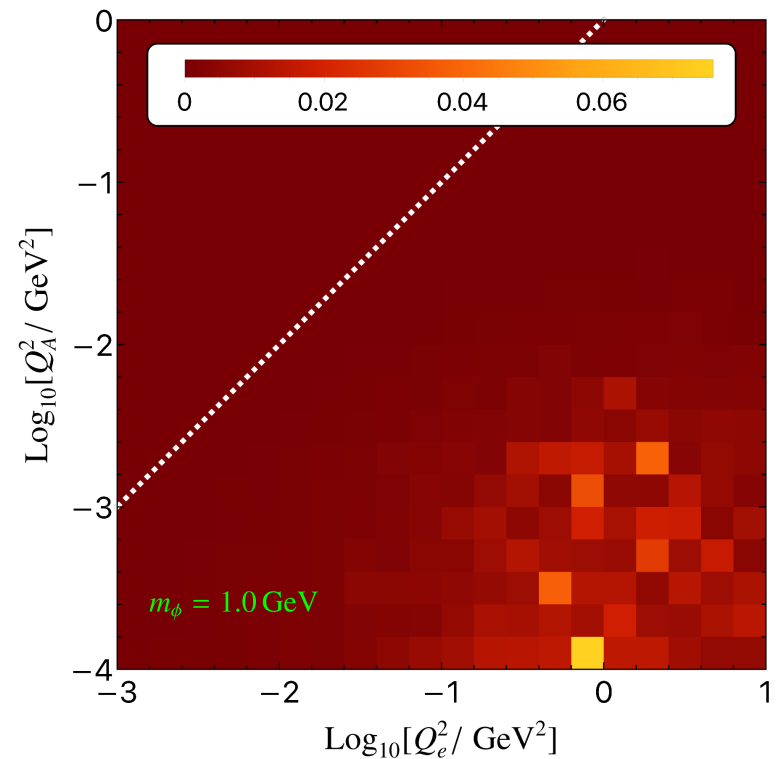

Maeda *et al.*, 1412.6880; Fry *et al.*, 2501.14827

m_ϕ [GeV]	$Q_{e,\min}^2$ [GeV ²]	$p_{T,e}^{\min}$ [GeV]	η_e^{\min}	η_e^{\max}	E_e^{\max} [GeV]	$\sigma_B^{\text{eff,cut}}$ [pb]
0.010	$10^{-0.7}$	1.1	-3.5	-1.5	10.0	0.58
0.032	$10^{-0.7}$	1.1	-3.5	-1.5	10.0	0.58
0.100	$10^{-0.7}$	1.1	-3.5	-1.5	10.0	0.58
0.316	$10^{-0.7}$	1.1	-3.5	-1.5	10.0	0.58
1.000	$10^{0.2}$	1.3	-3.5	2.0	10.0	0.53
1.585	$10^{0.5}$	1.3	-3.0	2.0	10.0	0.53
2.512	$10^{0.8}$	1.3	-2.5	2.5	10.0	0.41
3.981	$10^{1.2}$	1.3	-2.5	1.0	10.0	0.19
5.000	$10^{1.4}$	1.3	-3.0	1.0	10.0	0.11
6.310	$10^{1.5}$	1.3	-2.0	3.5	10.0	0.081
10.000	$10^{1.5}$	1.3	-1.5	3.0	10.0	0.081

- Additional leverage from Zero Degree Calorimeter to veto incoherent scattering

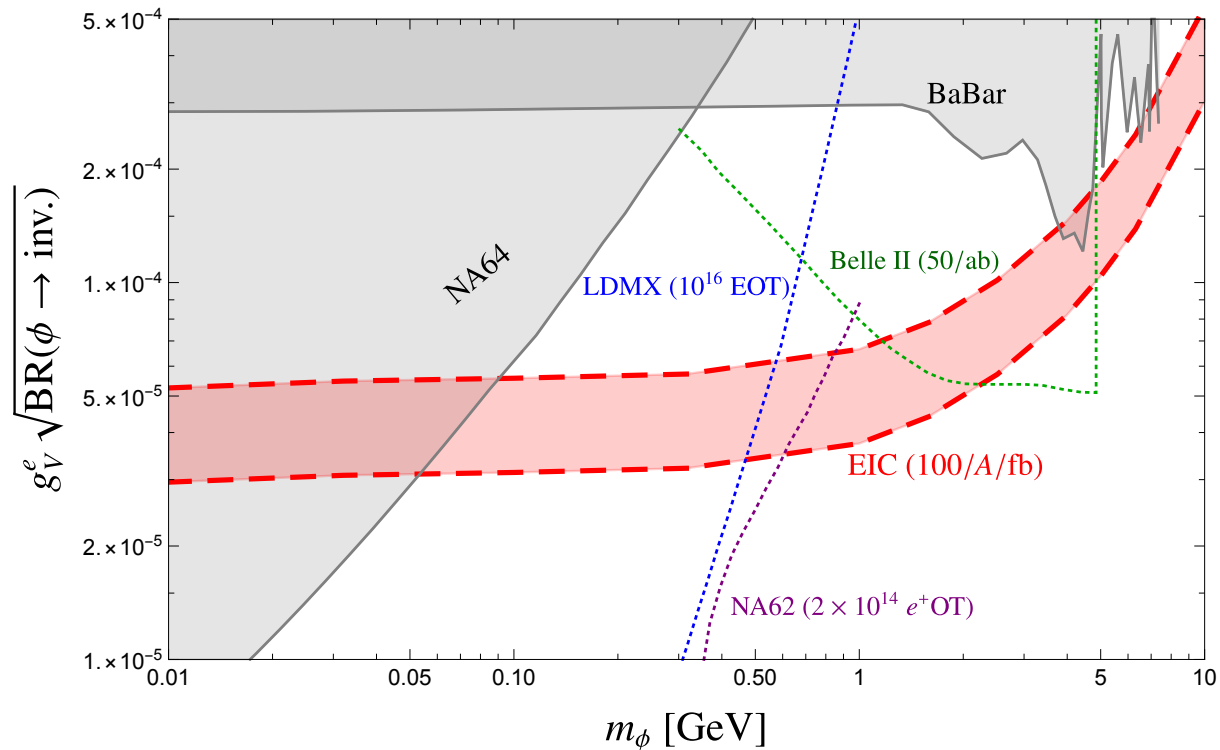

Plot revised from version in H.D., Liu, 2505.08871; red band: 2σ reach for $10^{-6} \leq \epsilon \leq 10^{-5}$

B. Coherent exclusive electro-production Balkin *et al.*, 2601.00068, 2604.08667

- Recent work considering particles coupled to hadrons Figures from 2601.00068

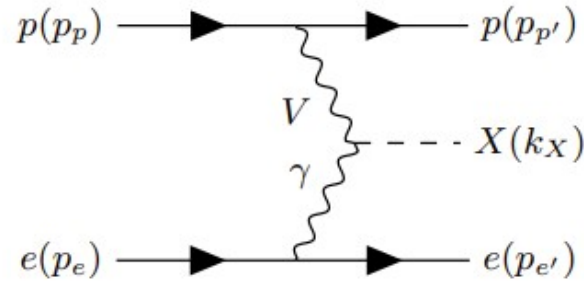

$X = \pi^0, \eta, \eta', a$ (ALP) and $V = \rho^0, \omega, \phi$

- ALP: coupled to gluons, decays invisibly into dark states $\text{BR}(a \rightarrow \bar{\chi}\chi) \approx 1$

$$\mathcal{L}_a \supset \frac{\alpha_s}{4\pi} \frac{a}{f_a} G^{\mu\nu} \tilde{G}_{\mu\nu} + ig_{a\chi} a \bar{\chi} \gamma^5 \chi$$

- In this channel expect $E_e \approx E_{e'}$ Balkin *et al.*, 2604.08667
- Signal: forward proton with reduced energy, little additional detector activity

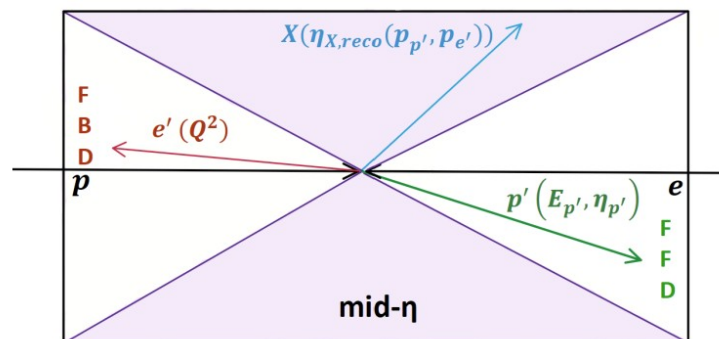

- Both on-shell and off-shell production
 - On-shell: $a \rightarrow \text{inv.}$
 - Off-shell: meson $\rightarrow \text{inv.}$ via meson-ALP mixing

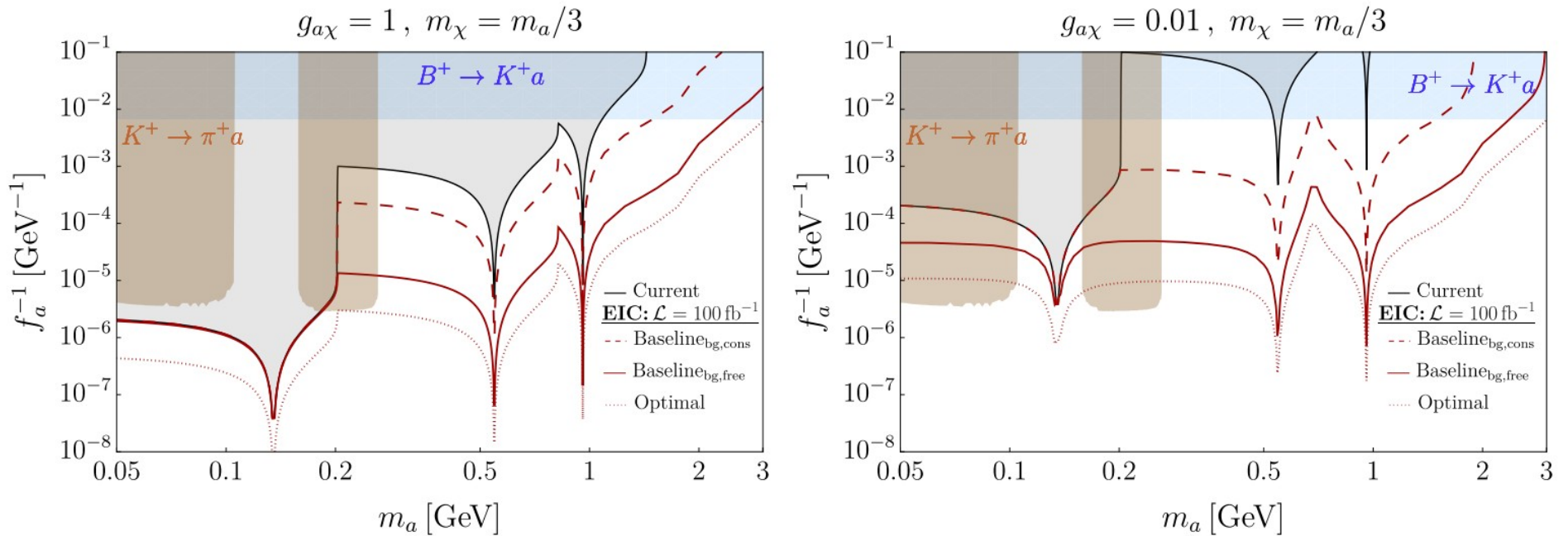

From 2601.00068

Baseline: $(E_p, E_e) = (100, 10)$ GeV; Optimal: $(E_p, E_e) = (41, 5)$ GeV

Left (right): dominated by invisible meson (ALP) decay

Concluding Remarks

- Open fundamental questions strongly imply the need for new physics
- There are currently no solid hints about the nature and scale of new particles
- Longstanding theory arguments are challenged, no new consensus has emerged
 - Motivates looking at a wide range of testable ideas
 - Any new facility that can help along should be leveraged
- The EIC can be a tool to probe new phenomena
 - Imprints of high scale phenomena may leave a trace (encoded via EFTs)
 - Low mass dark sectors can be directly accessed
- We only sampled some ideas for BSM at EIC
- Further studies are warranted and can provide
 - Optimized scientific impact for the EIC
 - Science case for extensions, *e.g.* a second detector
 - A nexus of collaboration for the high energy and nuclear physics communities